

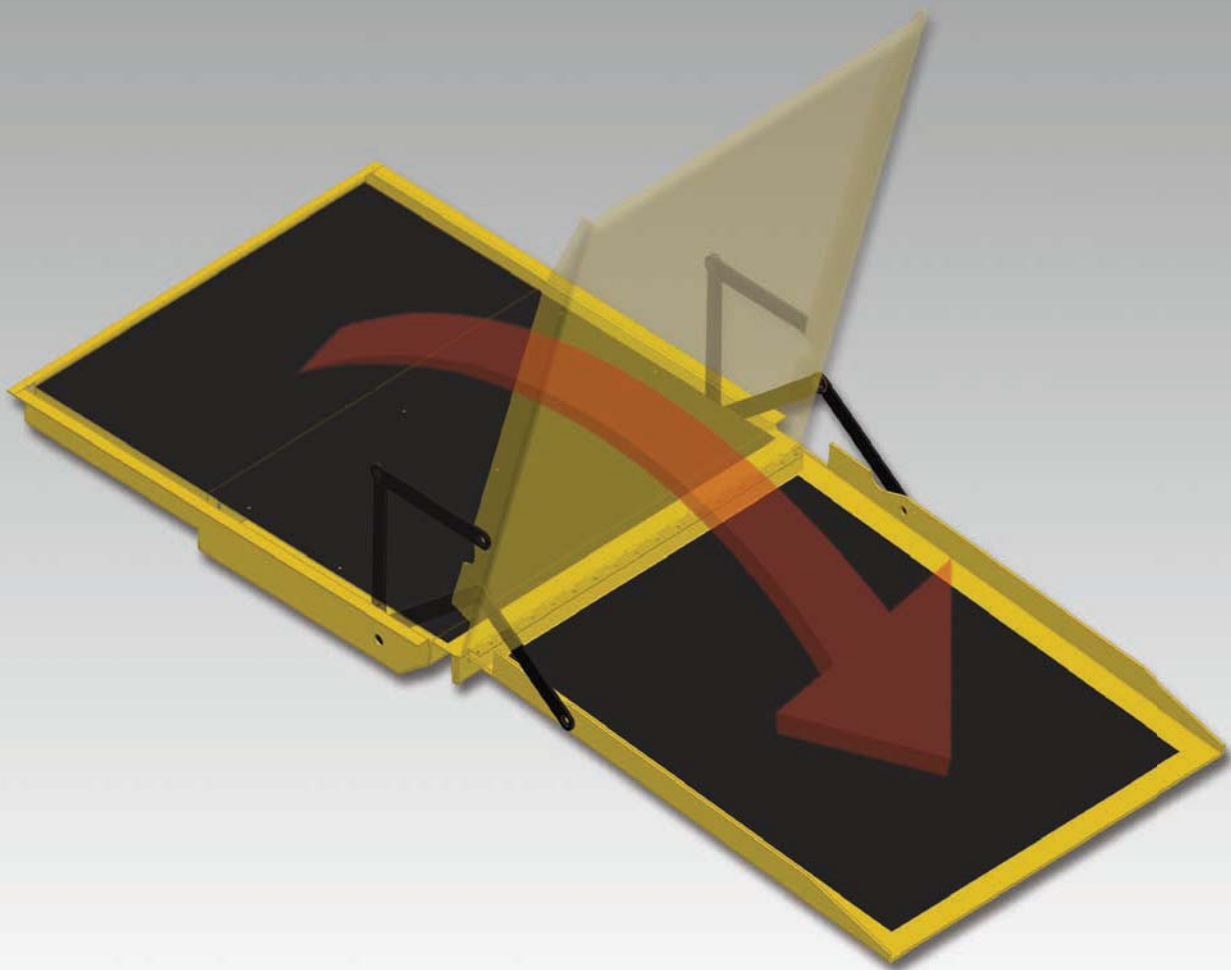

2018 Product Application Guide • 3-7-18



**RA400 TRANSIT RAMP**

## RA400 Transit Ramp Models

### FF3241Y-24V

RA400 Usable Width: 32" Usable Length: 41"

General Function: Electrohydraulic, power up/gravity down operation

Control: hand-held control box

Construction: Steel structure with powder coat finish

Power Supply: 24VDC

## RA400 Transit Ramp Features

- 32" wide ramp in 33.5" wide package
- self-contained, drop-in electric unit
  - no external pump
  - no dependence on vehicle hydraulics
  - no routing of hydraulic hoses
  - no pre-assembly of any kind
- "end of line" installation/quick "plug-in"
- 24 volt pump module
- smooth, quiet operation
- hydraulic up / gravity drift down
- simple manual override operation
- easy service/repair

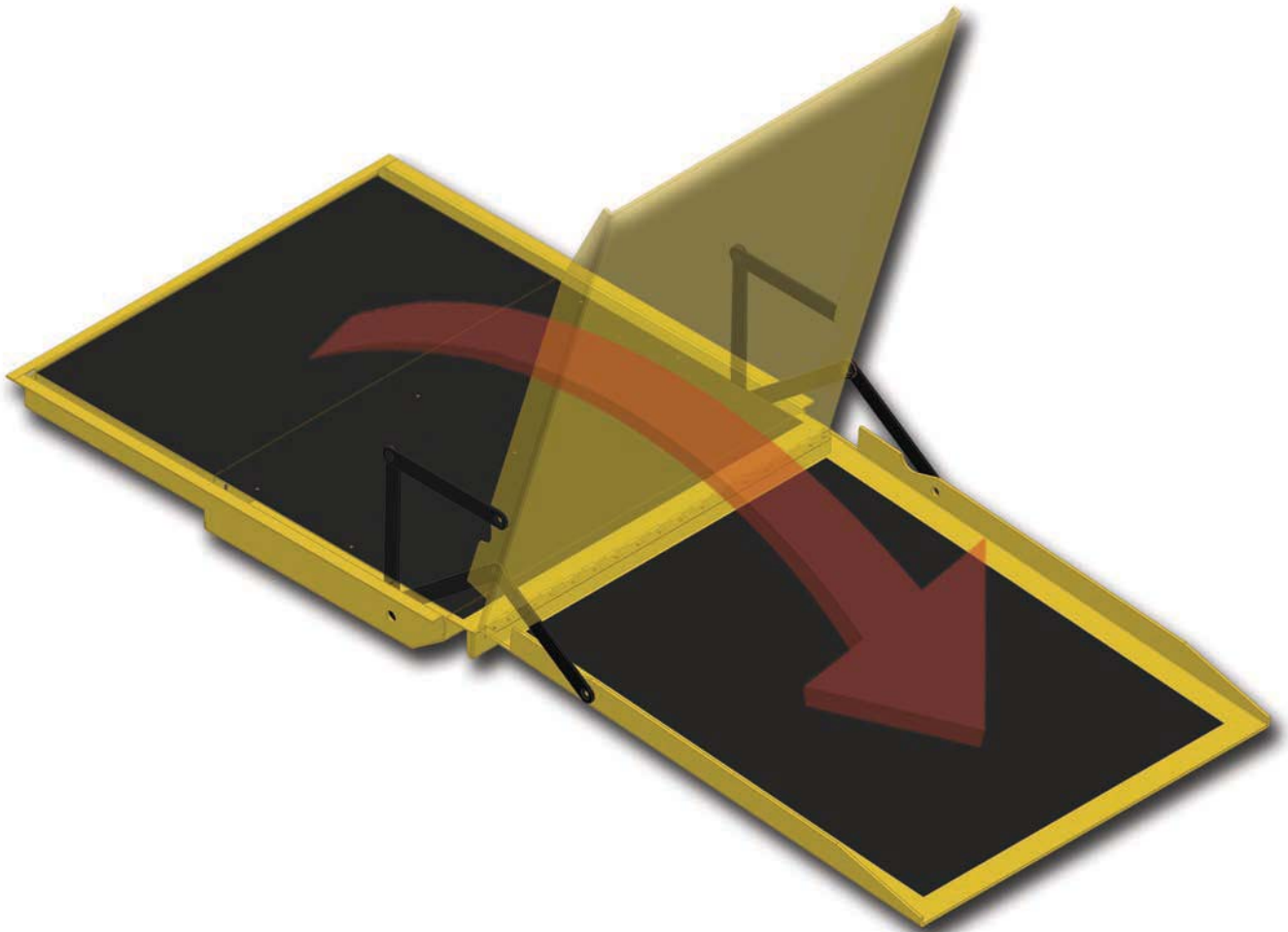

# RA400 Transit Ramp Dimensions

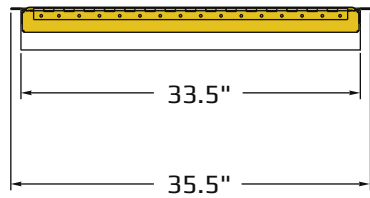
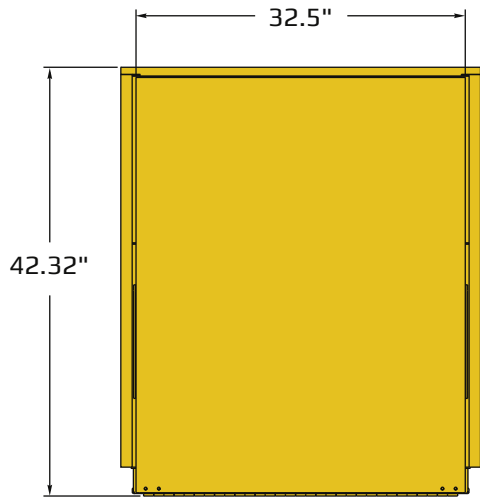

## STOWED VIEW

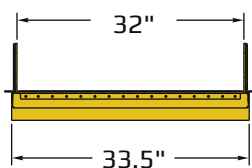
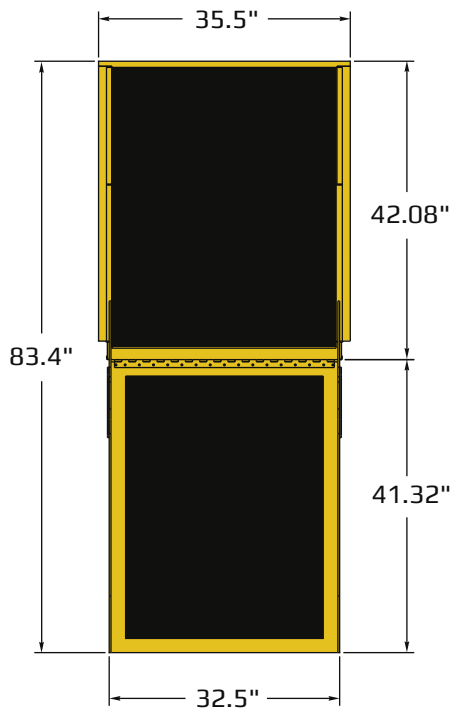
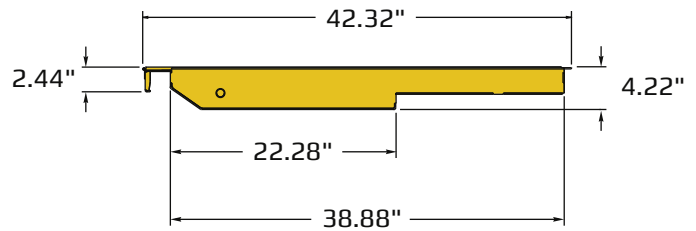
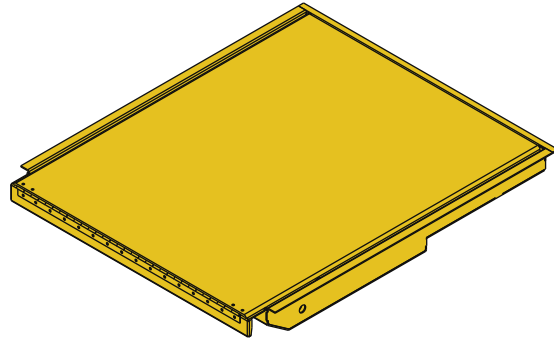

## DEPLOYED VIEW

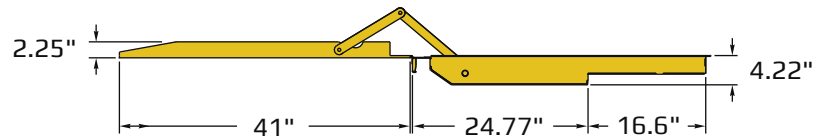
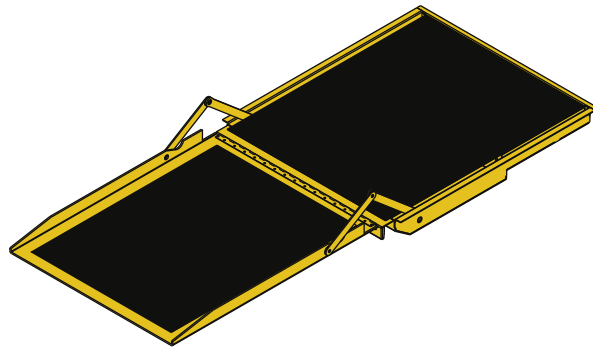

Power Unit: Hydraulic Pump Module  
 Voltage: 24 VDC  
 Current: 25 Amps (Max)  
 Inputs (Req'd): +24 volt supply  
 (-) Ground  
 Ramp "Out" signal (+)  
 Ramp "In" signal (+)

Unit Weight: 185 Lbs.

# RA400 Transit Ramp Specifications

## RA400 COMMERCIAL WHEELCHAIR RAMP SPECIFICATIONS IN COMPLIANCE WITH

**United States Department of Transportation Rules and Regulations 49CFR, Part 38.  
FROM THE AMERICANS WITH DISABILITIES ACT OF 1990  
"Provided to make your spec writing easier."**

The wheelchair ramp system shall be of modular steel frame construction requiring no pre-assembly or complex vehicle interface. The frame design shall provide rigidity for ramp alignment and ramp operation. The ramp shall have been tested to a minimum static load of 1,980#. The ramp shall have 660# rated capacity. The housing shall be of a welded box design to provide flexural rigidity to minimize ramp deflection when placed under load.

The power supply shall be a self-contained 24 volt electric hydraulic system operating two bi-directional cylinders requiring no dependence on vehicle hydraulic systems. The hydraulic power pack system shall be of modular design allowing for easy removal and field replacement, if needed. The operation of the unit shall provide a smooth deployment and stowage cycle. The power operation of the hydraulic cylinders shall be of a push-pull design for smooth operation and improved synchronous arm movement.

The ramp shall have a gravity-down feature to prevent vehicle jacking upon deployment, and ramp pinching upon stowage. The ramp system shall employ a pressure relief system to limit its ability to raise more than 50 pounds. Internal cylinder-mounted pressure compensator valves are not permitted.

A manual back-up system shall be provided to ensure operation of the ramp in case of electrical failure. The back-up system shall provide a reliable means of manually stowing and deploying the ramp. In back-up mode, the ramp shall be stowed and deployed with minimal physical effort requiring no special switching to accomplish the intended ramp motion.

The ramp shall permit easy access to all operating components without using special tools. The ramp shall be of aluminum construction with a stainless steel housing, and shall provide a continuous slip-resistant surface for safer use in inclement weather. The ramp shall have a minimum usable wheelchair passageway width of 32" and accommodate both four-wheel and three-wheel mobility aids.

The ramp shall be automatically folded and unfolded and fully automatic in operation. The ramp shall allow both inboard and outboard facing of wheelchair and mobility aid users.

The ramp shall be capable of operating for 15,600 cycles in a temperature range of -10 F to 115 F. The ramp should operate on vehicle grades up to 7 percent or 4 degrees.

When installed, the ramp shall have the least slope practicable and shall not exceed 1:4 when deployed to ground level. If the height of the vehicle floor from which the ramp is deployed is 3 inches or less above a 6-inch curb, a maximum slope of 1:4 is permitted. If the height of the vehicle floor from which the ramp is deployed is 6 inches or less, but greater than 3 inches above a 6-inch curb, a maximum slope of 1:6 is permitted. If the height of the vehicle floor from which the ramp is deployed is 9 inches or less, but greater than 6 inches above a 6-inch curb, a maximum slope of 1:8 is permitted. If the height of the vehicle floor from which the ramp is deployed is greater than 9 inches above a 6-inch curb, a slope of 1:12 shall be achieved.

The transition from roadway or sidewalk and the transition from vehicle floor to the ramp may be vertical without edge treatment up to 1/4 inch. Changes in level between 1/4 inch and 1/2 inch shall be beveled with a slope no greater than 1:2.

The sides of the ramp shall be a minimum of 2" high and be clearly marked for proper placement of the wheelchair.

All lift components shall be finished with a baked-on powder coating, which will meet a salt spray test of 1000 hours, to provide corrosion resistance and a long service life.



[braunability.com](http://braunability.com)

800.THE.LIFT

ISO 9001:2008

631 West 11th Street, Winamac, IN 46996, USA